

Alcatel-Lucent Enterprise OAW-AP Access Point Installation Guide

060436-11 Rev. D



enterprise.alcatel-lucent.com
Alcatel-Lucent and the Alcatel-Lucent Enterprise logo are trademarks of Alcatel-Lucent. To view other trademarks used by affiliated companies of ALE Holding, visit: enterprise.alcatel-lucent.com/trademarks. All other trademarks are the property of their respective owners. The information presented is subject to ALE without notice. Neither ALE Holding nor any of its affiliates assumes any responsibility for inaccuracies contained herein. (2016)

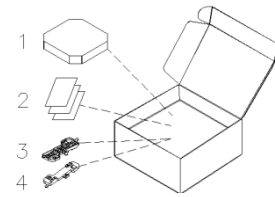

Figure1: Product Packing

Inform your ALE sales representative of incorrect, missing, or damaged parts. If possible, retain the carton, including the original packing materials. Use these materials to repack and return the unit to the supplier if needed. Additional mounting kits for use with the OAW-AP1101 access points are sold separately. Contact your ALE sales representative for details.

Unboxed OAW-AP1101:

- Net Weight: 0.60 lbs / 0.27 kg
- Dimensions (HxWxD): 6.1 inches x 6.1 inches x 1.1 inches (15.5 cm x 15.5 cm x 2.8 cm)

Device view

The OAW-AP access point is equipped with one hidden LED light that indicates different status with different color.

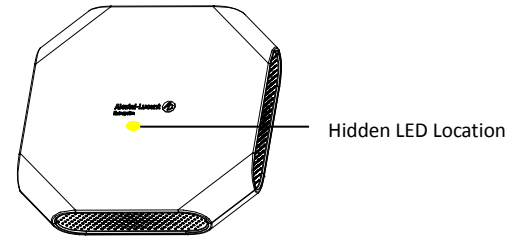

Figure 2: OAW-AP Access Point (Front View)

This document describes the packaging, AP layout, general process of installation as well as warnings and notices that need to be addressed prior to installation. It's recommended that the entire document be read prior to installation. All new AP installations are typically performed in the following sequence:

- Unpack the AP and check all items in the box.
- WLAN Planning. Usually, a comprehensive site survey is required before installation. There are many factors to consider such as coverage area, power supply to the AP, location of AP brackets, etc.
- Install the AP bracket on wall or ceiling.
- Install communications outlet (if new outlet is installed) label and test.
- Install each AP to bracket.
- Connect patch cord to port on AP.
- Connect patch cord to outlet.
- Verify post-installation connectivity.
- Configure each AP.

Access points are radio transmission devices and are subject to governmental regulation. Network administrators who are responsible for the configuration and operation of access points must comply with local broadcast regulations. Specifically, access point must use channel assignments appropriate to the location where the access point will be deployed.

Package Contents

Item	Name	Qty	Unit
1	Access Point	1	Pcs
2	Quick Start Guide	1	Pcs
	Installation Guide	1	Pcs
	User Guide Info Card	1	Pcs
3	Mounting Bracket (15/16")	1	Pcs
4	Mounting Bracket (9/16")	1	Pcs

Item Name	Specifications
Ethernet Port	The OAW-AP is equipped with one 10/100/1000Base-T (RJ-45) auto-sensing, MDI/MDX wired-network connectivity port.
Console Port	The console port is an RJ-45 female connector and can be used to connect to a terminal for direct local management. Note: Currently for use by Service & Support only.
DC Power Socket	The OAW-AP has a single 48V DC power jack socket to support powering through an AC-to-DC power adapter, If PoE is not available, an optional AC-DC adapter kit (sold separately) can be used to power the OAW-AP.
Security Lock Slot	The OAW-AP is equipped with a security lock slot for additional security.

Table 1: OAW-AP Connections

Pre-installation

FCC Statement: Improper installation of access points in the United States configured to non-US model controllers will be in violation of the FCC rules. Any such willful or intentional violation may result in a requirement by the FCC for immediate termination of operation and may be subject to forfeiture (refer to 47 CFR 1.80). **EU Statement:** Low power radio LAN product operating in 2.4 GHz and 5 GHz bands. Please refer to the ALE OS User Guide for details on restrictions.

For product available in the USA/Canada market, only channel 1-11 can be operated. Selection of other channels is not possible. This device is restricted for indoor use.

Pour les produits disponibles aux États-Unis / Canada du marché, seul le canal 1 à 11 peuvent être exploités. Sélection d'autres canaux n'est pas possible. Pour une utilisation en intérieur uniquement.

Dynamic Frequency Selection (DFS) for devices operating in the bands 5250- 5350 MHz, 5470-5600 MHz and 5650-5725 MHz.
Sélection dynamique de fréquences (DFS) pour les dispositifs fonctionnant dans les bandes 5250-5350 MHz, 5470-5600 MHz et 5650-5725 MHz.

The device for operation in the band 5150-5250 MHz is only for indoor use to reduce the potential for harmful interference to co-channel mobile satellite systems.

les dispositifs fonctionnant dans la bande 5150-5250 MHz sont réservés uniquement pour une utilisation à l'intérieur afin de réduire les risques de brouillage préjudiciable aux systèmes de satellites mobiles utilisant les mêmes canaux.

Users should also be advised that high-power radars are allocated as primary users (i.e. priority users) of the bands 5250-5350 MHz and 5650-5850 MHz and that these radars could cause interference and/or damage to LE-LAN devices.

De plus, les utilisateurs devraient aussi être avisés que les utilisateurs de radars de haute puissance sont désignés utilisateurs principaux (c.-à-d., qu'ils ont la priorité) pour les bandes 5250-5350 MHz et 5650-5850 MHz et que ces radars pourraient causer du brouillage et/ou des dommages aux dispositifs LAN-EL.

Pre-Installation Checklist

Before installing your OAW-AP access point, be sure that you have the following items:

- 4- or 8-conductor, CAT5 or better UTP cable of required length.
- One of the following power sources:
 - IEEE 802.3af-compliant Power over Ethernet (PoE) source (The POE source can be any power source equipment (PSE) controller or mid-span PSE device.
 - 48 V/0.6A DC AP AC-DC adapter kit (sold separately)
- A terminal or a notebook

Identifying Specific Installation Locations

You can mount the OAW-AP on a ceiling rail (using the included bracket) or on a wall (using the wall mount adapter, sold separately). You should first determine the location of the installation. The installation position is located at the center of the required coverage area and should be free from obstructions or obvious sources of interference.

- Minimize the number of obstructions (such as walls) between the AP and user terminals.
- Electronic equipment or devices (such as microwave ovens) which may produce radio frequency noise should be away from the installation position of the AP.

It is strictly prohibited to install around stagnant water, water seepage, leakage or condensation. Avoid cable condensation or water seepage along the cables connecting to the AP.

Temperature and Humidity requirement

- Operating temperature: 32°F to 113°F(0°C to 45°C)
- Storage temperature: -40°F to 158°F(-40°C to 70°C)
- Relative Humidity: 5% to 90% non-condensing

AP Installation

Using Ceiling Mounting Bracket

Make sure the AP fits securely on the ceiling tile rail when hanging the device from the ceiling, poor installation could cause it to fall onto people or equipment.

The OAW-AP has been shipped with two mounting brackets for 9/16" and 15/16" ceiling rails. Following is the general sequence to install the OAW-AP with the mounting bracket.

- Pull the cables through a prepared hole in the ceiling tile near where the AP will be placed.
- Place the bracket against the back of the AP, insert by aligning the slot on the backside with the hanging feet on both sides of the bracket (see Figure 4) .
- Push the bracket along the direction of the arrow until it locks in the slot (see Figure 4).
- Connect the cable to the port on the AP.
- Hold the AP next to the ceiling tile rail with the ceiling tile rail mounting slots at approximately a 20-degree angle to the ceiling tile rail (see Figure 5). Make sure that any cable slack is above the ceiling tile.
- Pushing toward the ceiling tile, rotate the AP clockwise until the device clicks into place on the ceiling tile rail(see Figure 5).

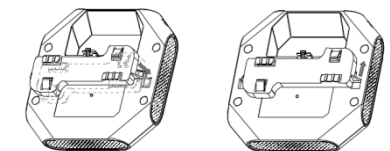

Figure 4: Attaching Ceiling Mounting Bracket

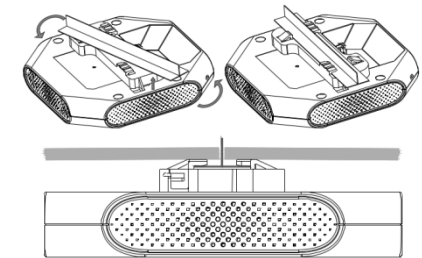

Figure 5: Mounting AP

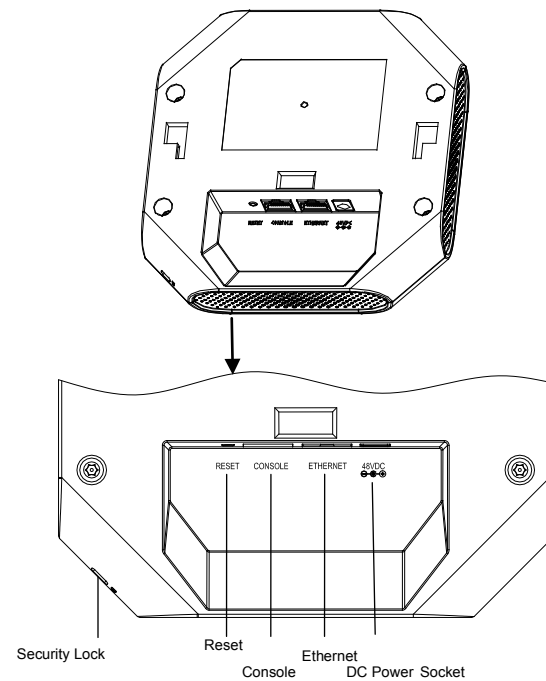

Figure 3: OAW-AP Access Point (Back View)

Connect Ethernet

Use the Ethernet port to connect the AP with a twisted pair Ethernet LAN segment. Use a 4- or 8-conductor, Category 5 UTP cable. The port is an RJ-45 female connector with the pinouts shown in Table 2.

Connector	Pin	Signal Name	GE	FE	PoE
	1	RJ45_DA+	BI_DA+	RX+	PoE-
	2	RJ45_DA-	BI_DA-	RX-	PoE-
	3	RJ45_DB+	BI_DB+	TX+	PoE+
	4	RJ45_DC+	BI_DC+	Spare	PoE+
	5	RJ45_DC-	BI_DC-	Spare	PoE+
	6	RJ45_DB-	BI_DB-	TX-	PoE+
	7	RJ45_DD+	BI_DD+	Spare	PoE-
	8	RJ45_DD-	BI_DD-	Spare	PoE-

Table 2: Ethernet Port Pinout

Connect Power Sources

Confirm that you have an IEEE 802.3af-compliant Power over Ethernet (PoE) source on the Ethernet cable, if not, connect by using the ALE 48V DC AP AC-DC adapter kit (sold separately) to the DC Power Socket and AC power jack.

If both POE and DC power are available, the use of DC is preferred. OAW-AP supports the power adapter provided by ALE ONLY.

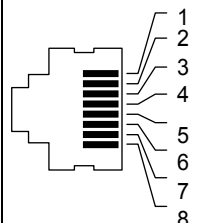
Verifying Post-Installation Connectivity

The LED on the AP can be used at this point to verify that the AP is receiving power and initializing successfully (see Table 3).

Red	Blue	Green	Time Line	Status
ON			Power on	
ON			Bootloader-OS loading	System start up
Flash			System running	Network abnormal (Interface down)
		Flash	System running	Network normal, without SSID created
		ON	System running	Network normal, single band working, either 2.4Ghz or 5Ghz
	ON		System running	Network normal, dual bands working, 2.4Ghz and 5Ghz are both working
Flash	Flash		System running	Red and Blue LEDs alternate flashing in specific frequency; OS upgrading
Flash	Flash	Flash	System running	3 LEDs alternate flashing in specific frequency; Used for locating an AP

Table 3: OAW-AP LED Meaning

Console Port

The serial console port allows you to connect the AP to a serial terminal or a laptop for direct local management. This port is an RJ-45 female

connector with the pinouts described in Table 4.

Note: Currently for use by Service & Support only.

Connector	Pin	Signal Name	Function	
	3	TXD	Transmit	
	4	GND	Ground	
	5	GND	Ground	
	6	RXD	Receive	
	Pins not listed are not connected.			

Table 4: Console Port Pinout

Configuring the OAW-AP

Refer to the Quick Start Guide and Configuration Guide for complete details.

Regulatory Compliance

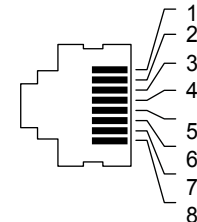
ALE USA Inc., hereby declares that this OAW-AP model is compliant with the essential requirements and other provisions of Directive 2014/53/EU. For the complete CE DoC, please access the website below to get more information: service.esd.alcatel-lucent.com

Waste Electrical and Electronic Equipment (WEEE) Statement

ALE products are subject to separate collection and treatment in the EU Member States, Norway, and Switzerland when they are at end of life, and therefore are marked with the symbol shown. The treatment applied to these products in these countries shall be compliant with the applicable national laws which are under the implementing of Directive 2012/19/EU on Waste of Electrical and Electronic Equipment (WEEE).



European Union RoHS

ALE products are compliant with the EU Restriction of Hazardous Substances Directive 2011/65/EU (RoHS). EU RoHS restricts the use of specific hazardous materials in the manufacture of electrical and electronic equipment. The restricted materials under the Directive are Lead (including Solder used in printed circuit assemblies), Cadmium, Mercury, equivalent Chromium, and Bromine.

FCC Class B Part 15 and Industry Canada license-exempt RSS standard(s):

This device complies with Part 15 of the FCC Rules. Operation is subject to the following two conditions:

- This device may not cause harmful interference.
- This device must accept any interference received, including interference that may cause undesired operation.

This device complies with Industry Canada license-exempt RSS standard(s). Operation is subject to the following two conditions: (1) this device may not cause interference, and (2) this device must accept any interference, including interference that may cause undesired operation of the device.

Le présent appareil est conforme aux CNR d'Industrie Canada applicables aux appareils radio exempts de licence. L'exploitation est autorisée aux deux conditions suivantes : (1) l'appareil ne doit pas produire de brouillage, et (2) l'utilisateur de l'appareil doit accepter tout brouillage radioélectrique subi, même si le brouillage est susceptible d'en compromettre le fonctionnement.

Any changes or modifications to this unit not expressly approved by the party responsible for compliance could void the user's authority to operate this equipment.

This equipment has been tested and compliant with the limits for a Class B digital device under part 15 of the FCC Rules. This equipment generates, uses and can radiate radio frequency energy. If it is not installed and used in accordance with ALE's instructions, it may cause harmful interference. If this equipment does cause interference, which can be determined by turning the equipment off and on, the user is encouraged to correct the interference by one or more of the following ways:

- Reorient or relocate the antenna.
- Increase the separation between the equipment and other devices.
- Connect the equipment to an outlet on a circuit different from that to which the other device is connected.
- Consult the dealer or an experienced radio technician for help.

Complies with the Class B limits for radio noise emissions as set out in the

interference-causing equipment standard entitled "Digital Apparatus," ICES-003 of Industry Canada.

California Proposition 65 Warning

WARNING: This product contains chemicals known to the State of California to cause cancer and birth defects or other reproductive harm.

RF Radiation Exposure Statement: This equipment complies with FCC, IC and CE RF radiation exposure limits. This equipment should be installed and operated with a minimum distance of 20 cm between the equipment and a human's body for 2.4 GHz and 5 GHz operations. This transmitter must not be co-located or operating in conjunction with any other antenna or transmitter. Cet équipement est conforme aux limites d'exposition aux rayonnements IC établies pour un environnement non contrôlé. Cet équipement doit être installé et utilisé avec un minimum de 20 cm de distance entre la source de rayonnement et votre corps.

All operational modes:

2.4GHz: 802.11b, 802.11g, 802.11n (HT20), 802.11n (HT40)
5GHz: 802.11a, 802.11ac (VHT20), 802.11ac (VHT40), 802.11ac (VHT80)

For Model OAW-AP1101, the frequency, mode and the maximum transmitted power in EU are listed below:

2412-2472MHz (802.11n HT20 MCS0): 19.97dBm
5180-5240MHz (802.11ac VHT40 MCS0): 22.70dBm
5260-5320MHz (802.11a 6 Mbps): 22.89dBm
5500-5700MHz (802.11a 6 Mbps): 28.27dBm

Regulatory Certifications

TRA REGISTERED	NO:
ER49813/16	
DEALER	NO:
DA57199/16	

Complies with IMDA Standards [DA1073476]

This telecommunication equipment conforms to NTC technical requirement.

Contacting Alcatel-Lucent Enterprise

Website Support	
Main Site	http://enterprise.alcatel-lucent.com
Support Site	http://support.esd.alcatel-lucent.com
Telephone Support	
North America	1-800-995-2696
Latin America	1-877-919-9526
Europe	+800 00200100 (Toll Free) or +1(650)385-2193
Asia Pacific	+65 6240 8484
Other Region	1-818-878-4507

[REMAINING SECTIONS INTENTIONALLY LEFT BLANK]